

DesignLine

roommate

MODEL MHP10 INSTALLATION, OPERATION & MAINTENANCE MANUAL



THROUGH-THE-WALL
INDOOR HEAT PUMP

SAFETY AND INSTRUCTIONS	2	INTERNAL WIRING	14
OPERATION	3	FUNCTIONS	15
REFRIGERANT	3	WIFI SETUP AND SMART FEATURES	16
SPECIFICATIONS	4	RESISTANCE-TEMPERATURE CONVERSION TABLE ..	22
HEATING/COOLING PERFORMANCE	5	TROUBLESHOOTING	21
PRODUCT OVERVIEW	6	ERROR CODES	25
WHATS INCLUDED	7	SERVICING	27
INSTALLATION	8	REPLACEMENT PARTS	29
TOOLS REQUIRED	9	WARRANTY	31
CONTROLS	12		

DesignLine

 A MESTEK COMPANY

260 North Elm Street, Westfield, MA 01085
Tel: (413) 564-5545
7555 Tranmere Drive, Mississauga, Ontario, L5S 1L4 Canada
Tel: (905) 670-5888
www.designlinevac.com



Safety and Instructions

READ ALL INSTRUCTIONS BEFORE USE.

Your safety and the safety of others are very important.

Prior to installing the unit, please read through this installation manual in its entirety as there are important safety measures and warnings that need to be adhered to. Failure to comply with safety measures and warnings in this manual can result in a void of warranty as well as injury to the installer.



This symbol shows that this unit uses a flammable refrigerant. If the refrigerant is leaked and exposed to an external ignition source, there is a risk of fire.

WARNING You may be killed or seriously injured if you do not follow instructions.

CAUTION You may be injured or cause damage to the product if you do not follow instructions.

WARNING To reduce the risk of explosion, fire, death, electric shock, scalding, or injury to persons when using this product, follow basic precautions including the following:

Read Before Installation

Before use, the unit must be properly installed as described in this manual.

Contact an authorized service technician for repair or maintenance of this unit.

Contact a qualified installer to properly install this unit.

When the power cord is to be replaced, replacement work shall be performed by authorized personnel using only genuine replacement parts.

Installation work must be performed in accordance with the National Electric Code by qualified and authorized personnel only.

Connect to a properly rated, protected, and sized power circuit to avoid electrical overload. Always plug into a grounded outlet. The unit shall always have +/-10% of voltage applied at all times. If there is the possibility of voltage drop or voltage spike, an appropriately rated surge protecting device must be installed to protect the unit. If the unit experiences a surge or drop in voltage and there is no protection, nuisance errors and other electrical damage may occur. This will void the warranty.

Do not under any circumstances, cut or remove the third (ground) prong from the power cord.

When installing or moving the unit, be careful not to pinch, crush, or damage the power cord.

Plug in the power plug properly.

Do not modify or extend the power cord.

Do not start/stop operation by plugging/unplugging the power cord.

If the cord/plug is damaged, have it replaced by an authorized service person using authorized replacement parts.

Use a dedicated circuit.

Do not disassemble or modify the product.

Adhere to all industry recommended safety procedures including the use of long-sleeved gloves and safety glasses.

Use care when unpacking and installing. The edges of the product may be sharp.

Disconnect the power cord or circuit breaker before installing or servicing the unit.

Keep packaging materials out of the reach of children. These materials can pose a suffocation risk to children.

Store and install the product where it will not be exposed to temperatures below freezing or exposed to outdoor weather conditions.

Do not store or use any flammable vapors/liquids such as gasoline in the vicinity of this or any appliance.

Operation

Use this unit only for its intended purpose.

Never attempt to operate this unit if it is damaged, malfunctioning, partially disassembled, or has missing/broken parts. This includes a damaged cord or plug.

Repair or immediately replace all power cords that have become frayed or otherwise damaged.

Do not use a cord that shows cracks or abrasion damage along its length or at either end.

Do not run cord under carpets or mats where it could be stepped on and damaged.

Keep the cord out from under heavy objects like tables or chairs.

Do not place the power cord near a heat source.

Do not use an adaptor or plug the product into a shared outlet.

Do not tamper with controls.

If you detect a strange sound, a chemical or burning smell, or smoke coming from the unit, unplug it immediately, and contact an authorized technician.

Never unplug the unit by pulling on the power cord. Always grip the plug firmly and pull straight out from the outlet.

Do not grasp the power cord or touch the unit controls with wet hands.

Young children should be supervised to ensure that they do not play with the unit.

If water enters the product, turn off the power at the main circuit, then unplug the product and call for service.

If the product has been submerged, contact the an authorized technician for instructions before resuming use.

Unplug the product when unused for long periods.

Unplug the product before cleaning. In the event of a gas leak (propane gas, etc.) do not operate this or any other appliance. Open a window or door to ventilate the area immediately.

The appliance is not to be used by persons (including children) with reduced physical, sensory or mental capabilities, or lack of experience and knowledge, unless they have been given supervision or instruction. Children being supervised should not play with the appliance.

To clean the interior, contact an authorized technician. Using harsh detergents may cause corrosion or damage to the unit.

Do not use solvent-based detergent on the product. Doing so can cause corrosion or damage, product failure, electrical shock, or fire.

Grounding Instructions

The power cord of this unit is equipped with a three-prong (grounding) plug. Use this with a standard three-slot (grounding) wall power outlet to minimize the hazard of electric shock. The customer should have the receptacle and circuit checked by a qualified electrician to make sure the receptacle is properly grounded. **DO NOT CUT OR REMOVE THE THIRD (GROUND) PRONG FROM THE POWER PLUG.**

Situations when the unit will be disconnected occasionally; Because of potential safety hazards, we strongly discourage the use of an adapter plug. However, if you wish to use an adapter, a TEMPORARY CONNECTION may be made. Use UL-listed adapter, available from most local hardware stores.

The large slot in the adapter must be aligned with the large slot in the receptacle to ensure a proper polarity connection.

Attaching the adapter ground terminal to the wall receptacle cover screw does not ground the appliance unless the cover screw is metal, not insulated, and the wall receptacle is grounded.

Disconnect the power cord from the adapter, using one hand on each. Otherwise, the adapter ground terminal might break. Do not use the unit with a broken adapter plug. Do not use an adapter plug in situations when the unit will be disconnected often. Unplugging the power cord frequently can lead to eventual breakage of the ground terminal. The wall power outlet should be replaced by a three-slot (grounding) outlet instead.



Refrigerant

READ THE MAUAL CAREFULLY BEFORE USING THE UNIT. R32 refrigerant gas complies with international environmental directives. This unit contains approximately 19.40 Oz refrigerant gas.

WARNING

Do not accelerate the defrosting process or clean using chemicals other than those recommended by the manufacturer.

The unit shall be stored in a room without continuously operating ignition sources.

(For example: open flames, an operating gas appliance or an operating electric heater)

Do not pierce or burn.

Be aware that refrigerants may not contain an odor.

Precautions shall be taken to avoid excessive vibration or pulsation.

When using the product, any required ventilation openings must be kept clear of obstruction. Notice that servicing shall be performed only as recommended by the manufacturer.

Unventilated Area

An unventilated area where the unit using flammable refrigerants is installed shall be so constructed that should any refrigerant leak, it will not stagnate to create a fire or explosion hazard.

CAUTION The non-fixed unit shall be stored in an area where the size corresponds to the room area as specified for operation.

CAUTION The non-fixed unit shall be stored in a room without continuously operating open flames or other potential ignition sources.

The unit shall be stored to prevent mechanical damage from occurring.

Non-duct connected appliances containing A2L refrigerants with the supply and return air openings in the conditioned space may have the body of the appliance may be installed in open areas such as false ceilings not being used as return air plenums, as long as the conditioned air does not directly communicate with the air of the false ceiling.

Qualified Installers/Service Professionals

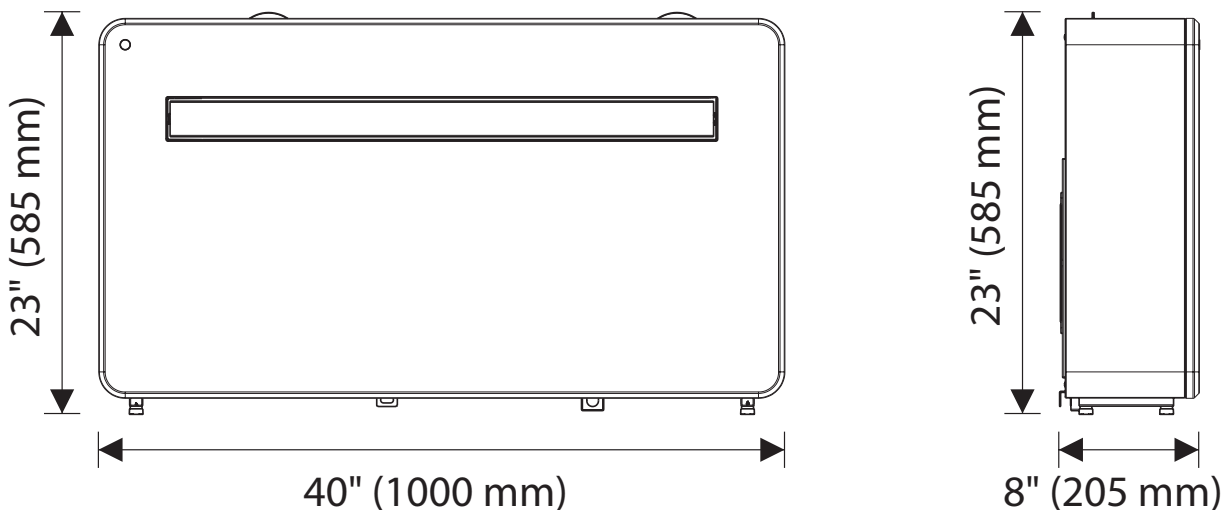
All operators or refrigeration circuit maintenance personnel should obtain a valid certificate issued by an industry-recognized evaluation agency.

Only perform equipment maintenance and repairs in accordance with the methods recommended by the unit manufacturer. If other personnel are required to assist in maintenance and repairs, they should be supervised by personnel qualified to use **flammable refrigerants**.

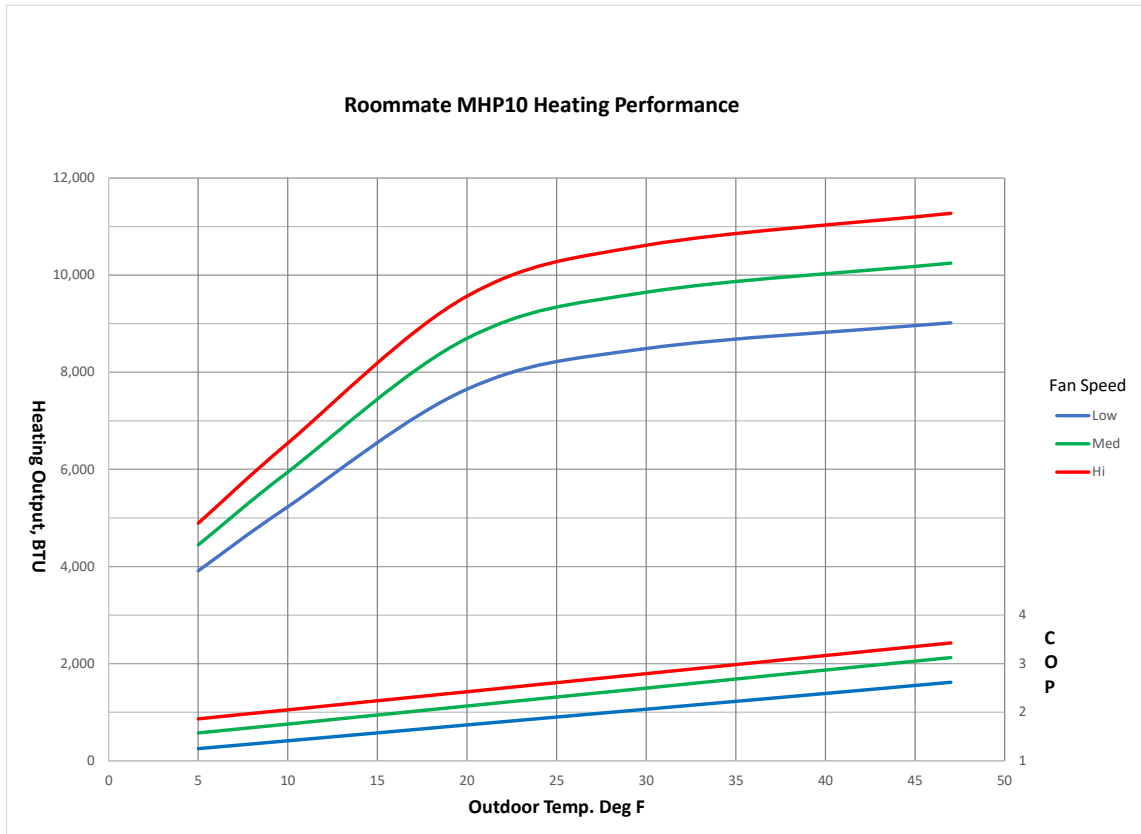
Specifications

		Units	MHP10
Cooling	Capacity Range	BTU/hr	1000-12000
	Efficiency Range	EER (BTU/W)	5-13
	Ambient Temp Range	°F (°C)	23-110 (-5-43)
Heating	Capacity Range	BTU/hr	1000-12000
	Efficiency Range	COP (W/W)	1.76-4.69
	Ambient Temp Range	°F (°C)	5 - 110 (-15 - 43)
Electrical	Power	V/Ph/Hz	115/1/60
	Fan Motor Exhaust	A	0.7
	Fan Motor Supply	A	0.15
	Compressor Motor	A	4.9
Refrigerant	Type		R32
	Factory Charge	lbs. (kg)	0.55 (0.25)
Fan	Quantity		1
	Power Input	W	25
	Type		Variable
	High Speed (Heat/Cool)	CFM	282/311
	Medium Speed (Heat/Cool)	CFM	247/277
	Low Speed (Heat/Cool)	CFM	194/194
Sound (@3meters)	Maximum	dBA	46
	Type		Inverter
Compressor	Speed Range	Hz	30-80
	Brand		GMCC
	Quantity		1
Dimensions	Net Dimensions (D x W x H)	inch (mm)	8 x 40 x 23 (205 x 1000 x 585)
	Shipping Dimensions (D x W x H)	inch (mm)	13 x 44 x 26 (330 x 1118 x 660)
	Net Weight	lbs. (kg)	94 (43)
	Shipping Weight	lbs. (kg)	107 (49)

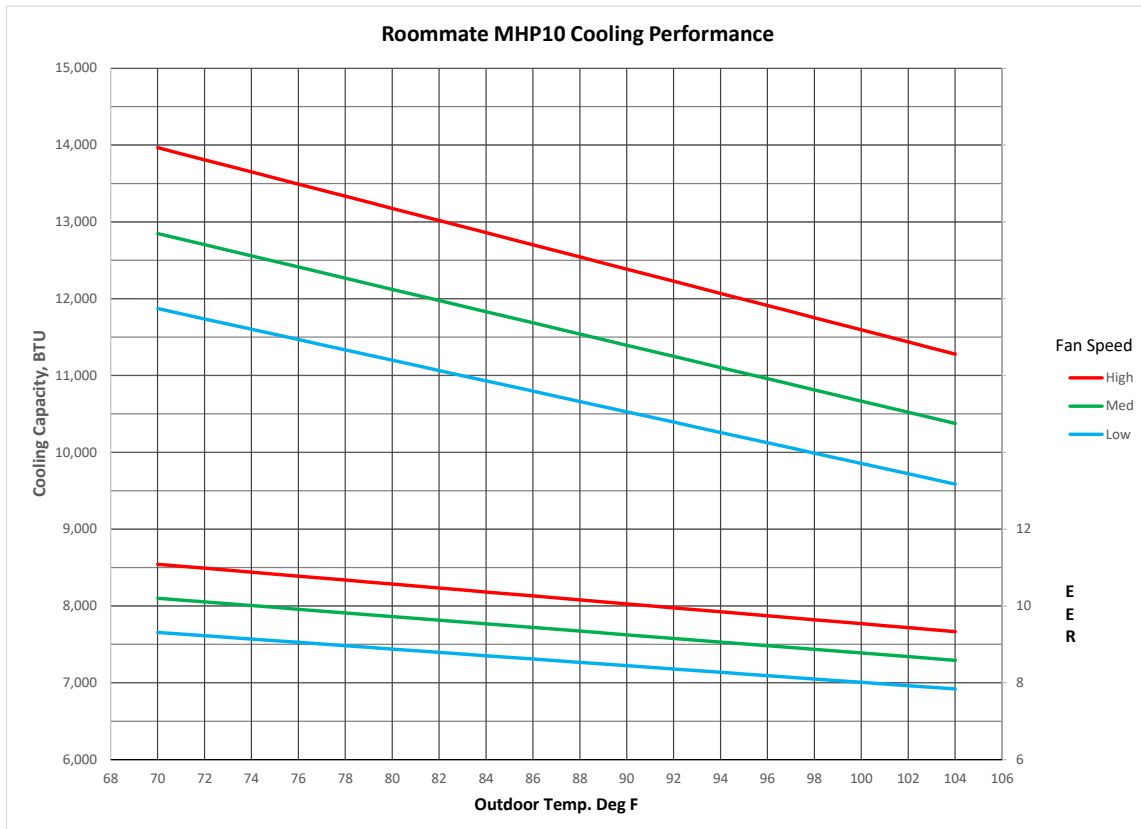
Dimensions



Heating Performance MHP10

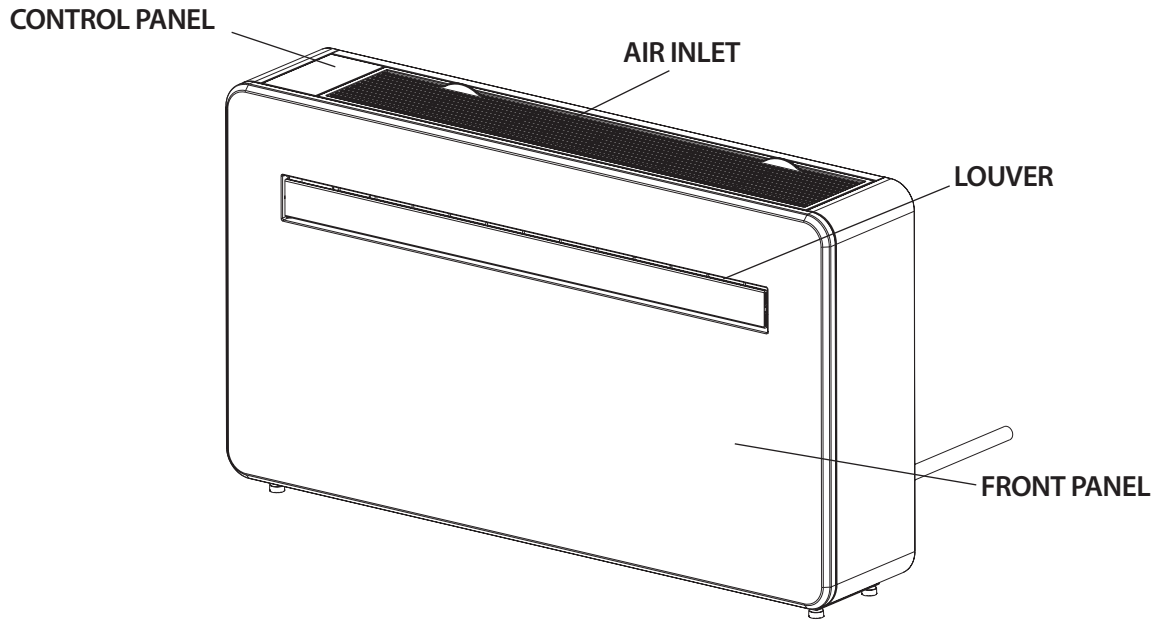


Cooling Performance MHP10

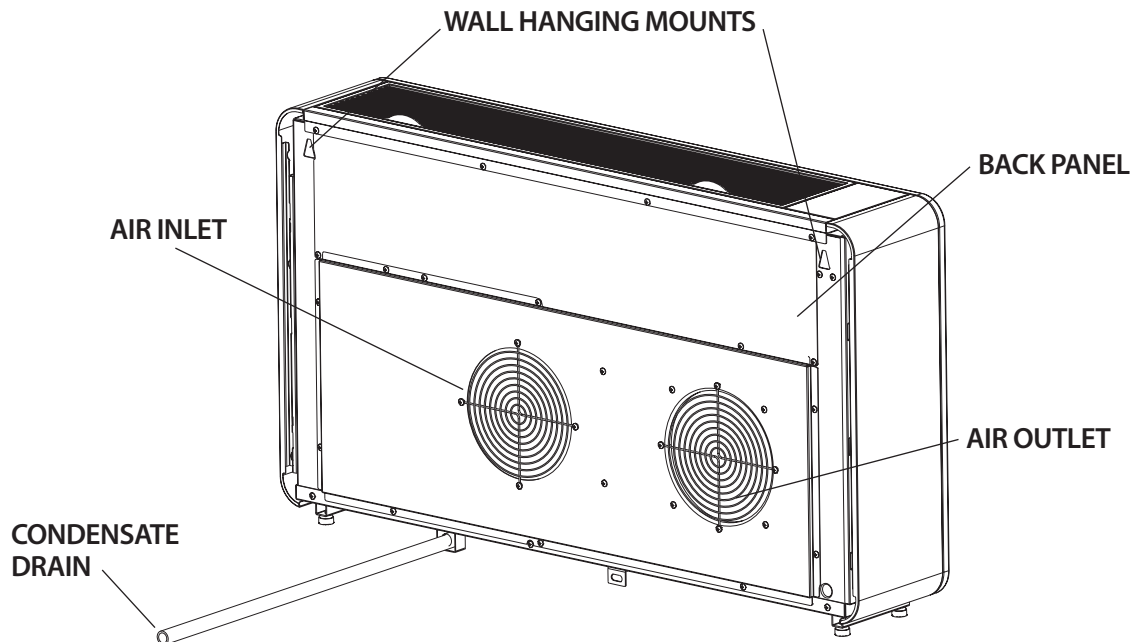


Product Overview

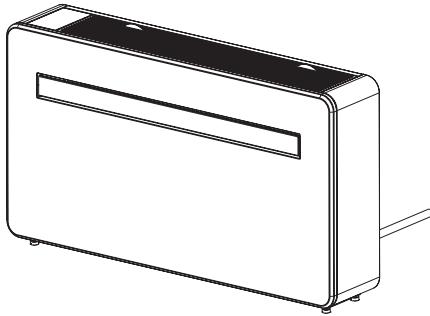
FRONT



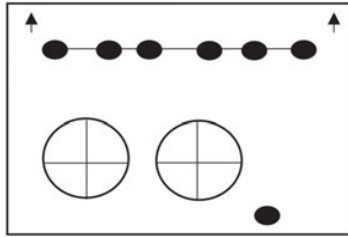
BACK



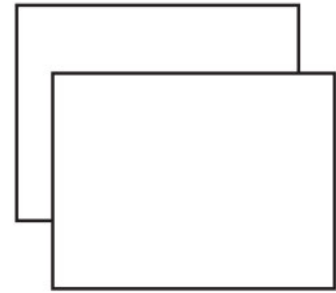
Whats Included



UNIT



WALL TEMPLATE



PLASTIC DUCTING SHEET (X2)



MOUNTING BRACKET



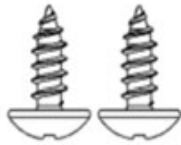
REMOTE CONTROL



**VENT COVER ASSEMBLY (X2)
(CHAIN, INDOOR RING AND
OUTDOOR COVER)**



FIXED PLATE



**2PCS TAPPING
SCREW
(4x10mm)**



**7PCS WALL PLUGS
(8x40mm)**



7PCS SCREWS (5x60mm)



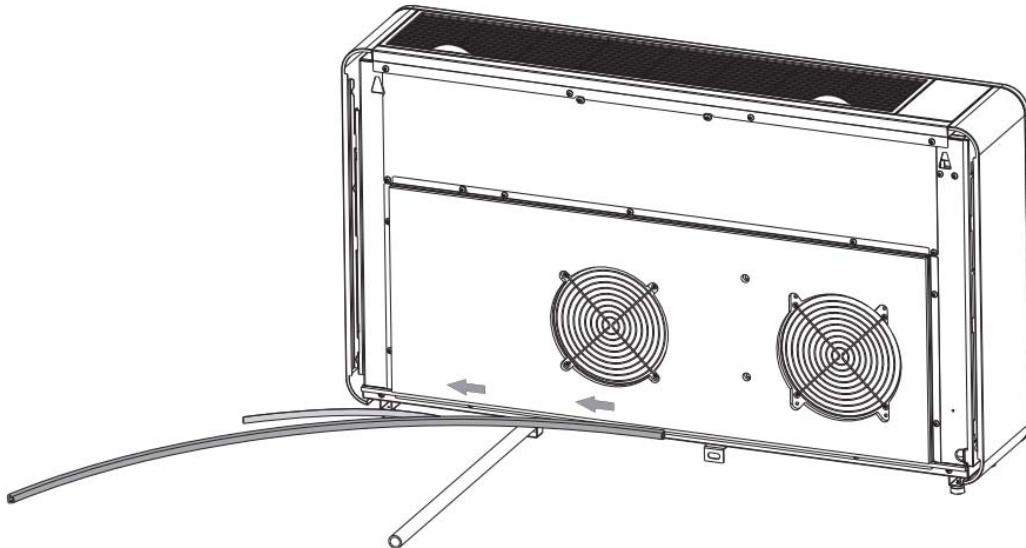
SEALING STRIP

(DIAGRAMS FOR ILLUSTRATIVE PURPOSES ONLY)

Installation

The sealing strip (provided) is intended to create an airtight seal between the mounting surface and the unit. It shall be installed on the unit prior to securing to any surface. It is intended to "stick" (self-adhesive) so the back of the unit in the placement shown in the diagram below. It is meant to fit securely around the rear panel. It may be necessary to cut off excess material. The rear panel shall be cleaned, and any debris shall be removed to ensure a proper adhesion.

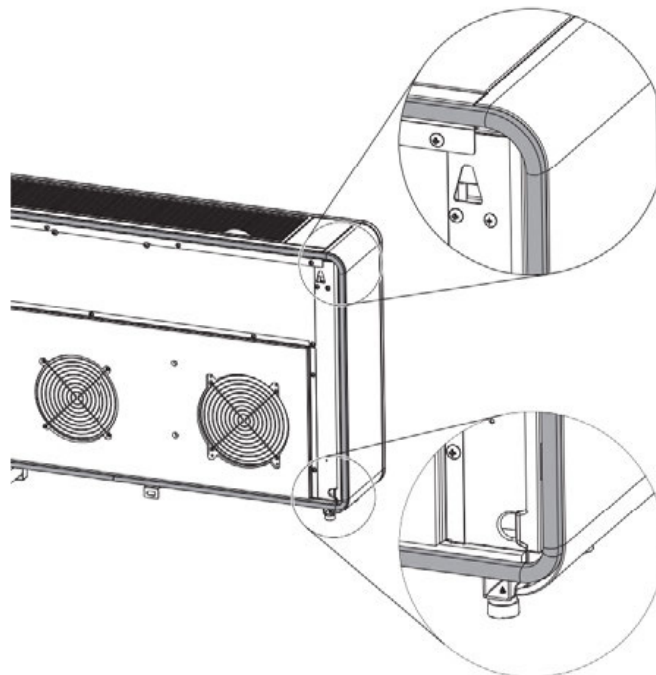
Figure 1



- Note:
1. The sealing strip should be adhered along the edge of the unit, as shown in Figure 1.
 2. Please peel the striping layer on the sealing strip gradually while adhering.
 3. Adhere from the bottom of the unit first.

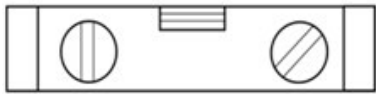


Figure 2

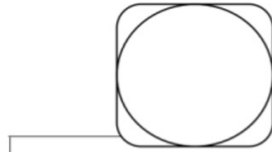


4. The position of the corner should be adhered as shown in Figure 2.
5. Improper adhesion may cause extra noise.

Tools Required



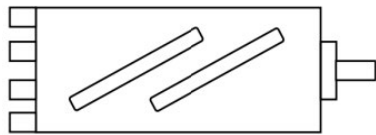
LEVEL



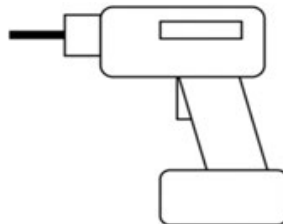
TAPE MEASURE



PENCIL



7.1 in/180mm HOLE SAW



DRILL



SHARP KNIFE



8mm MASONRY DRILL BIT



25mm MASONRY DRILL BIT

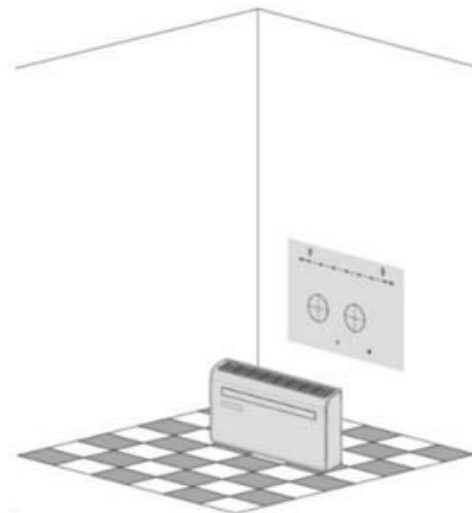
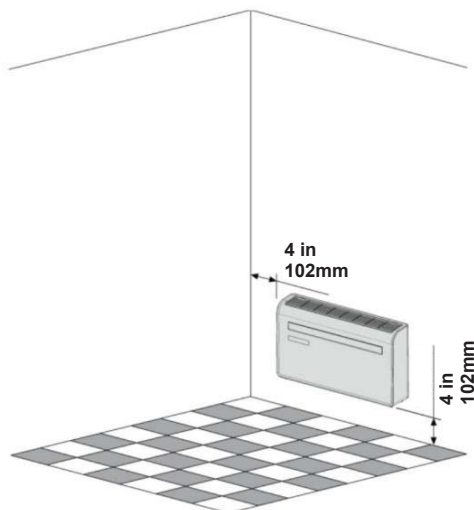
ENSURE UNIT MOUNTING LOCATION IS WITHIN 6' OF AN APPROVED 3-PRONG ELECTRICAL OUTLET. UNITS COME STANDARD 115/1/60 BUT ARE ALSO AVAILABLE WITH 230/1/60 SO IT IS IMPERATIVE YOU HAVE THE PROPER ELECTRICAL CONFIGURATION FOR THE EQUIPMENT.

BEFORE STARTING INSTALLATION, PLEASE ENSURE YOU HAVE ALL SUITABLE EQUIPMENT AVAILABLE AND UNDERSTAND THE STEPS INVOLVED IN INSTALLATION. IF IN ANY DOUBT, PROFESSIONAL ADVICE SHOULD BE SOUGHT.

THE INSTALLER MUST ENSURE THAT THE PLANNED POSITION OF THE AIR CONDITIONER IS SUITABLE, AND THAT THERE ARE NO CABLES AND PIPES INSIDE THE WALL, NO OTHER OBSTRUCTIONS FIXED ON THE WALL, WHICH WOULD PRESENT A DANGER AND/OR PREVENT COMPLETION OF INSTALLATION.

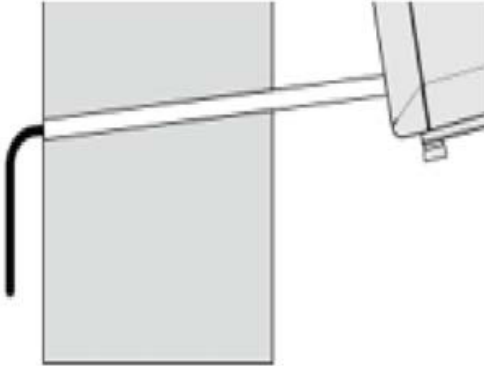
This unit must be installed on an external wall, as it vents directly out of its rear, ensure the wall is flat, solid, level, and structurally sound. The wall must be cleaned and prepared before installation.

Leave at least 4 in/102mm of space to the left, right and base of the unit. At least 8 in/203mm of space must be left above the unit to help air flow smoothly and stay away from curtains, plants, faucets, furniture and others appliances etc.

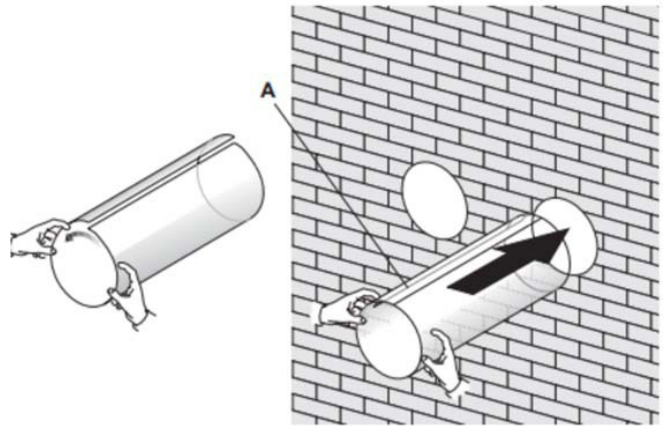


Paste the supplied installation template paper in position on the wall, ensuring that the reference line is level using a spirit level. The wall should be level both horizontally and vertically.

The hole for the drain pipe must be drilled using a 25mm drill bit. Ensure the hole is at a downward angle in accordance with local building codes so that the water will drain correctly. Condensate drain shall be installed with provisions to be protected from freezing during cold climate conditions. Heat trace and installing into an internal drain are suitable alternatives. If the condensate drain is not protected from freezing conditions, the unit can be severely damaged and will result in a loss of warranty. Please consult a professional if there is any question about the condensate location.



As seen in image "A" roll the plastic vent sheets into a tube and feed them from the inside into the holes previously made. Ensure the tubes sit flush to the interior wall. It is important to seal the seam created by rolling the plastic vent sheet ductwork. This can be achieved by applying HVAC rated tape or glue (field supplied).



When required, on the exterior, trim off the excess vent tube using a sharp knife, keeping the edge as neat as possible.

The following instructions are used when utilizing the supplied ducting with the unit. If another type of ducting is required, the installer shall consult the manufacturer or use a manufactured approved alternate ducting method.

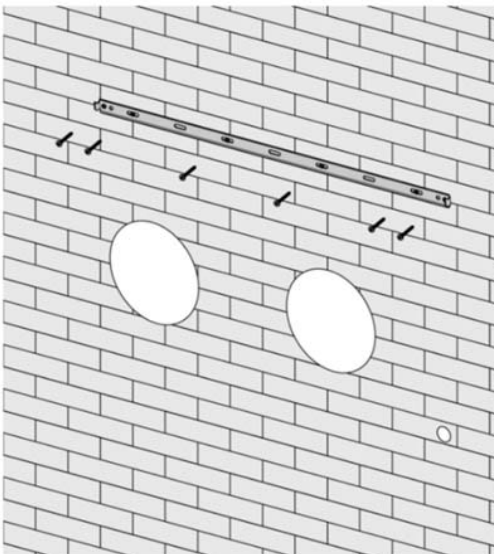
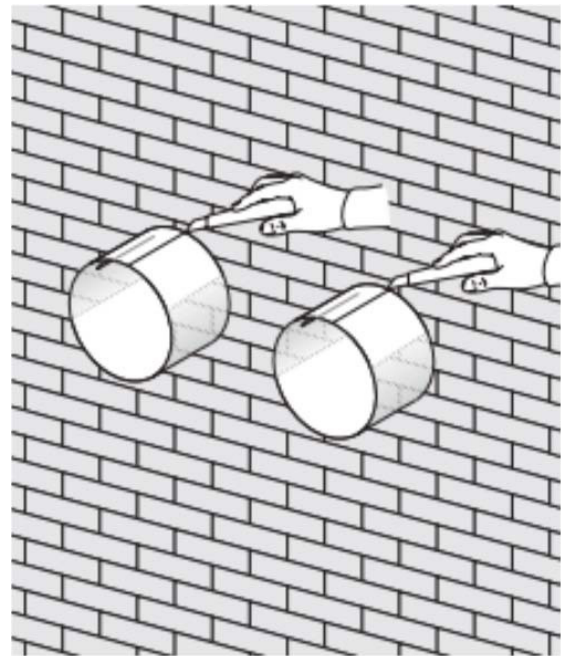
Use a 7.1 in/180mm hole saw to drill the two holes for the unit's ventilation, ensuring that the holes are at a downward angle (min 5 degrees) and aligned with the template.

Use the template to mark the position of the screws for the mounting bracket, using a level to ensure it is straight and level.

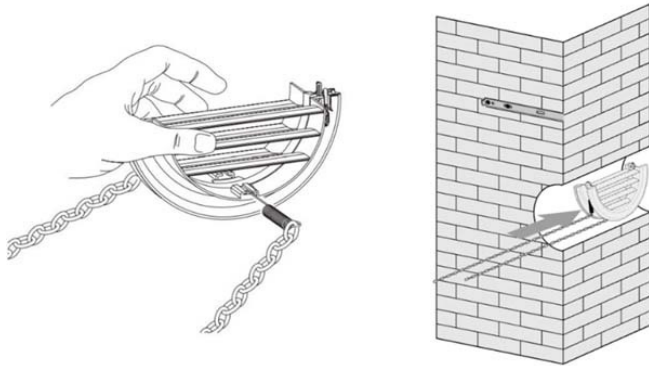
Drill the marked holes using a suitable 8mm drill bit and insert wall plugs. Line the mounting bracket with the holes and fix the bracket into position using the supplied screws. Please note, it is always best practice to secure the bracket into wall studs as available. However, if wall studs do not line up or are not available, please use provided wall anchors.

Ensure that the mounting bracket is securely fastened onto the wall, and that there is no risk of the unit tipping or falling. Follow all local building codes while mounting the unit.

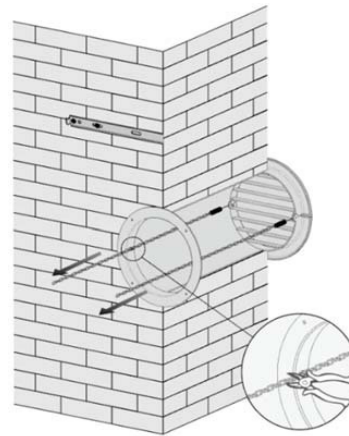
The unit performs best when it is installed on a wall with a thickness not exceeding 9.5 in /240mm.



Insert the indoor fixing ring from the vent cover onto the indoor side of the air vent. Then fold the external vent cover in half. Attach the chains to each side of the vent cover, before sliding the cover outside through the vent hole.



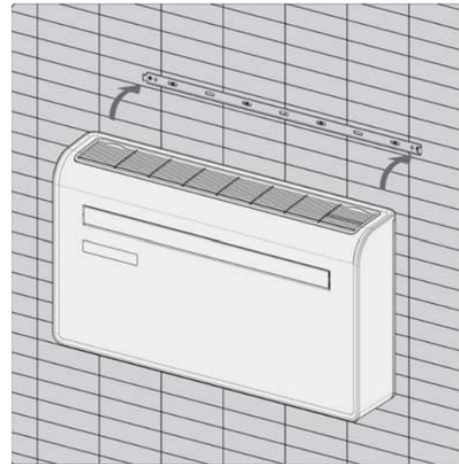
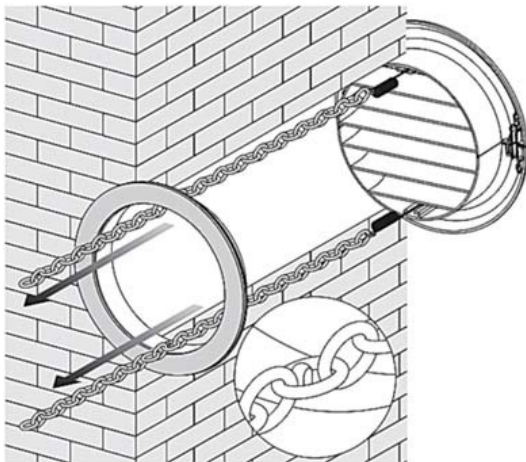
Once the chains are fitted and secure, any excess chain should be removed by cutting the chain.



Expand the external cover, before tightly fixing the chains by hooking onto the indoor fixing ring. This will hold the external cover firmly in position. Repeat for the second vent.

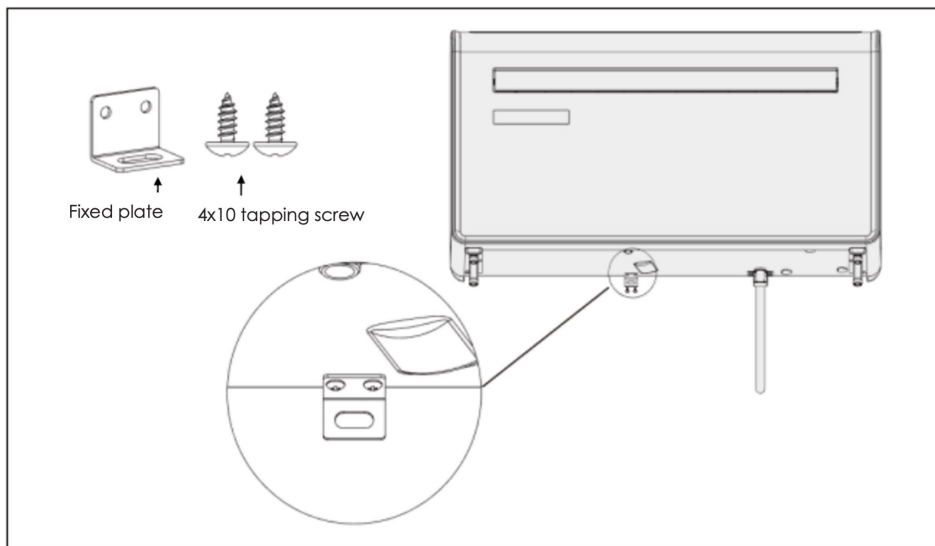
Lift the unit onto the wall, align the hanging holes with the hooks on the mounting bracket and gently rest the unit into place.

At the same time, slide the drainpipe through the drainage hole.



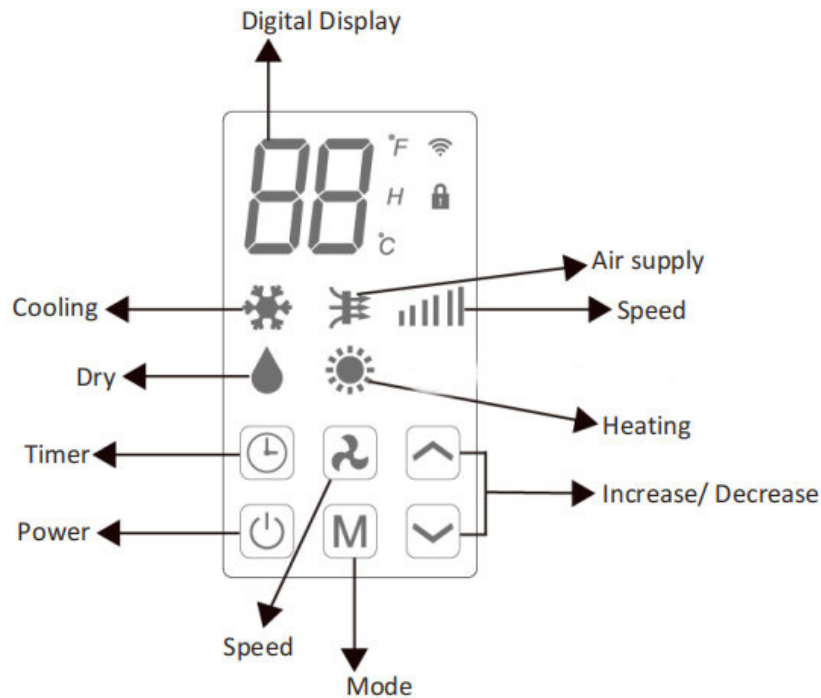
NOTE:

1. Please ensure that the backside of product is tightly attached on the wall to avoid additional vibration and noise.
2. The end of the external water pipe must be placed in an open space or drain. Avoid damage or restriction (pinching) to the condensate drain to ensure the unit drains properly.



Controls

Control Panel



Remote Control

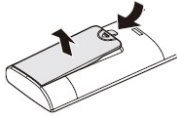
The unit can be controlled with the remote control. Two AAA-batteries are required.

NOTE: Further details of the functions can be found on the following page.

POWER	Press the POWER button to turn the unit on or off.	
MODE	Press the MODE button to switch between cooling, heating, fan, and dry modes.	
FAN	Press the FAN button to change between high, medium and low fan speeds	
LED	Press the LED button to open or close the LED background light of unit, it can be a choice for sleep condition.	
	Press the UP button to increase the desired temperature or timer duration	
	Press the DOWN button to decrease the desired temperature or timer duration	
SLEEP	Press for sleep mode. In Sleep mode, noise will be lower, the fan works in low speed so the noise will be less. Please note that in Sleep mode, the units capacity will be decreased. Only use Sleep mode when necessary	
SWING	Press to turn the louver swing function on and off. (Only activated by the remote control & APP)	
TIMER	Press the TIMER button to set the automatic switch on/off.	

NOTE: If the "Up" arrow and "Down" arrow are pressed together simultaneously, the unit can be changed from Farenheit to Celsius.

Inserting and Replacing Batteries



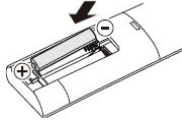
Your air conditioning unit comes with two AAA batteries. Put the batteries in the remote control before use.

1. Remove the cover on the back of the remote control.
2. Insert the new batteries and make sure that the (+) and (-) terminals of the batteries are installed correctly.

Battery Notes

For optimum product performance:

1. Do not mix old and new batteries, or batteries of different types.
2. Do not leave batteries in the remote control if you don't plan on using the device for more than 2 months.



Battery Disposal

Do not dispose of batteries as unsorted municipal waste. Refer to local laws for proper disposal of batteries.

Tips for Using Remote Control

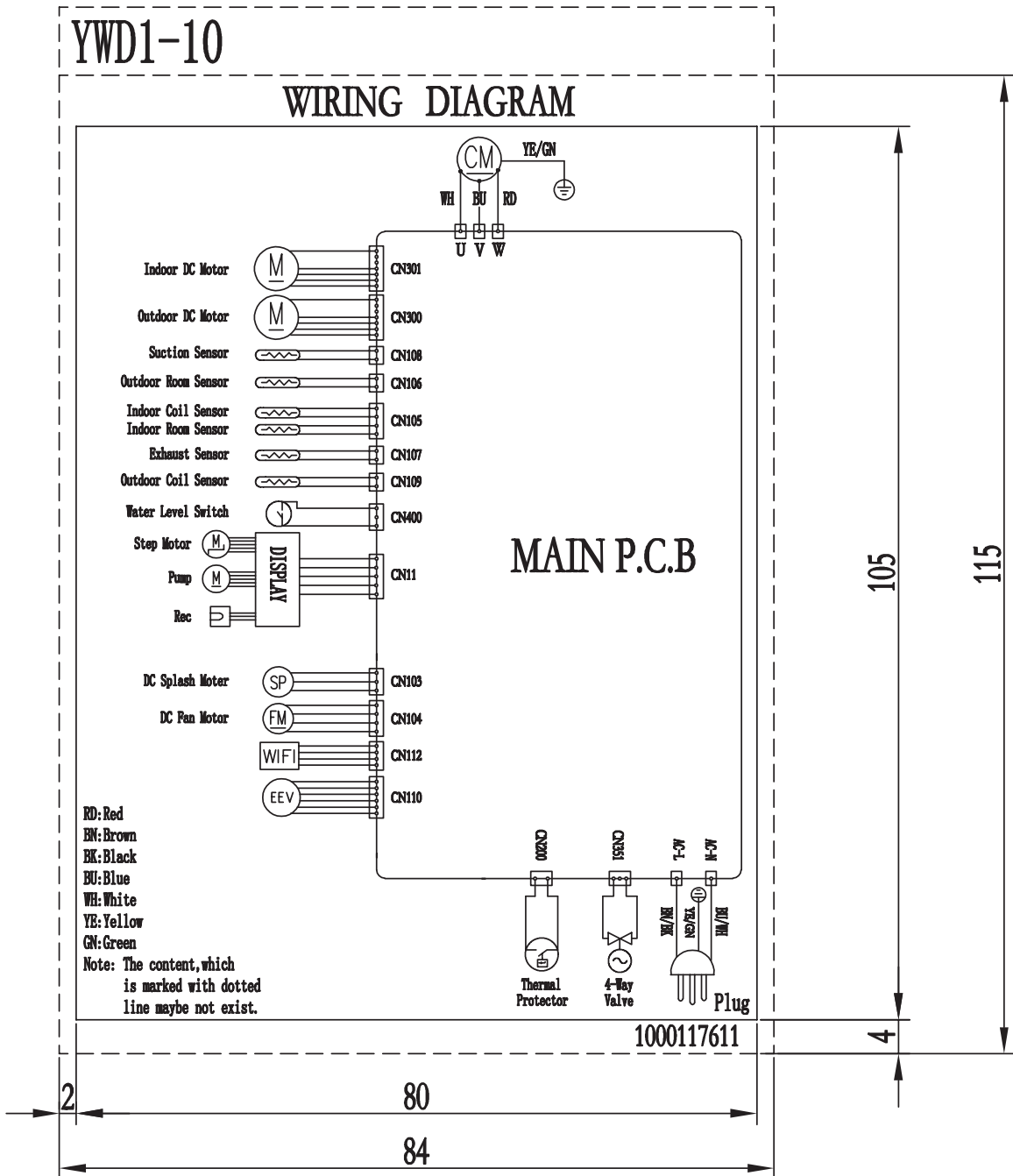
The remote control must be used within 26 feet / 8 meters of the unit.

The unit will beep when remote signal is received.

Curtains, other materials, and direct sunlight can interfere with the infrared signal receiver.

Remove batteries if the remote will not be used more than 2 months.












Internal Wiring



Wiring Diagram Component Definition

Diagram Call out	Definition
Indoor DC Motor	Motor that runs the main supply blower
Outdoor DC Motor	Motor that runs the main exhaust to outside
Suction Sensor	5k Sensor located on the suction line
Outdoor Room Sensor	5k sensor used to monitor the outdoor temperature
Indoor Coil Sensor	5k Sensor located on the indoor room coil
Indoor Room Sensor	5k Sensor monitoring the incoming air from the conditioned space
Exhaust Sensor	5k Sensor located on the discharge refrigerant line
Outdoor Coil Sensor	5k Sensor located on the outdoor coil
Water Level Switch	Float switch for drain pan
Step Motor	DC motor controlling the air discharge vane
Pump	Condensate Pump
REC	Receiver for remote control
Display	Main display located local to the product
DC Splash Motor	Fan motor for condensate
DC Fan Motor	Fan motor to dissipate heat from control board
WiFi	WiFi Module
EEV	Electronic expansion valve
CM	Compressor Motor
Thermal Protector	Fuse for current overload
4-Way Valve	Reversing valve
Plug	Main power cord (115v units only)

Functions

 POWER	Press the POWER button to turn the unit on or off.	
 MODE	Press the MODE button to switch between cooling, heating, fan and dry modes.	
	 COOLING	The cooling function allows the unit to cool the room and at the same time reduces air humidity. The desired temperature can be adjusted using the increase and decrease button between 60°F and 86°F. The fan speed can also be adjusted using the speed button.
	 DRY	Dry mode will extract moisture from the air, which will be drained outside using the installed drainpipe. the fan speed cannot be adjusted in dry mode.
	 FAN	In fan mode the unit will recirculate the air within the room, and will not cool, heat or dehumidify. The fan speed can be adjusted using the Speed button, But the desired temperature cannot be set.
	 HEATING	The heating function allows the unit to heat the room. The desired temperature can be adjusted using the increase and decrease button between 60°F and 86°F. The fan speed can also be adjusted using the speed button.
	 SLEEP	Sleep mode can be activated from APP or the remote control. It will only operate in cooling or heating modes, the fan speed will change to low, and noise will be lower. However, please note that during "sleep mode" the capacity of the unit will be reduced and may not satisfy the demand as needed.
 FAN SPEED		Press to change the fan speed between Low, Medium, and High. The fan speed cannot be adjusted in Dry or Sleep modes.
 TIMER	The unit contains a 24-hour timer, which can be used to either set a delayed start, or a set period of operation.	
	SHUTDOWN TIMER: While the unit is running press the timer button, the display will flash "0" 5 times. After the 5th flash, use the up and down buttons to adjust the duration in 1-hour increments between 1 to 24 hours. When the timer has elapsed, the unit will shut down automatically.	
DELAYED START TIMER: With the unit in standby, press the timer button, the display will flash "0" 5 times. After the 5th flash, use the up and down buttons to adjust the duration in 1-hour increments between 1 to 24 hours. After the timer has elapsed, the unit will start up in the same mode with the same settings as when it was turned off.		
 INCREASE AND DECREASE	Used within cooling and heating modes to adjust the desired temperature 60-86°F. Also used while setting the timer to adjust the duration.	
SWING MODE	After unit turns on, press the "SWING" button, louver will swing continuously up and down; by pressing the button again the movement will stop and the louver remain in that position. Swing mode can only be adjusted from the remote and will initially be turned on by default. the louver will close automatic once switch OFF the product.	
COMPRESSOR PROTECTION	There is a 3-minute delay on power on. To protect the life of the compressor and electronic components please do not switch on the unit for at least 5 minutes after you turned the unit off.	

Wifi Setup And Smart Features

Before You Start

Ensure your router provides a standard 2.4ghz connection.

If your router is dual band ensure that both networks have different network names (SSID). The provider of your router / Internet service provider will be able to provide advice specific to your router.

Place the unit as close as possible to the router during setup.

Once the app has been installed on your phone, turn off the data connection, and ensure your phone is connected to your router via WIFI.

Please note: When making changes via the app, the changes will be reflected in the app and on the local screen but the remote control display will not update to the change. For example: If the user sets a temp to 75°F (heating) on the remote, the app, local screen and remote will reflect this change. If the user changes the set point to 75°F on the app, the app, and local screen will change but the remote will not. Also, if the user then uses the remote next, the unit will automatically revert to the set point on the remote itself.

Download the App To Your Phone

Download the "SMART LIFE" app, from your chosen app store, using the QR codes below, or by searching for the app in your chosen store.



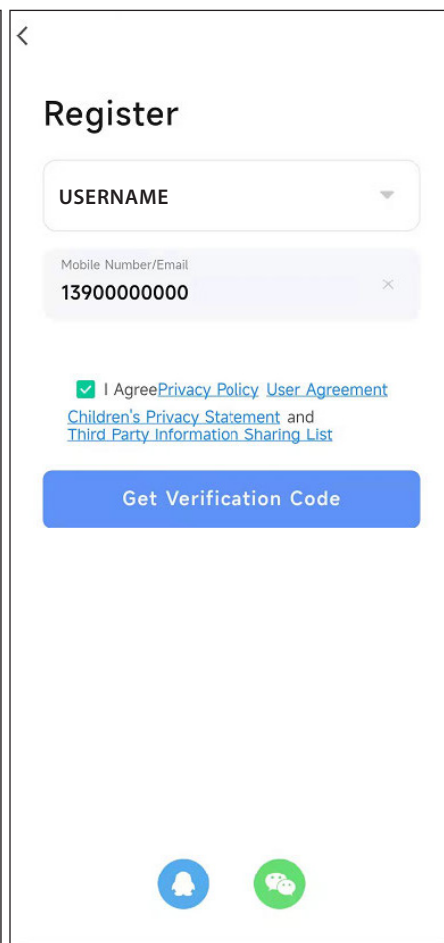
Register the App

If you don't have an App account, register an account or sign in with verification code by SMS. This page describes the registration process.

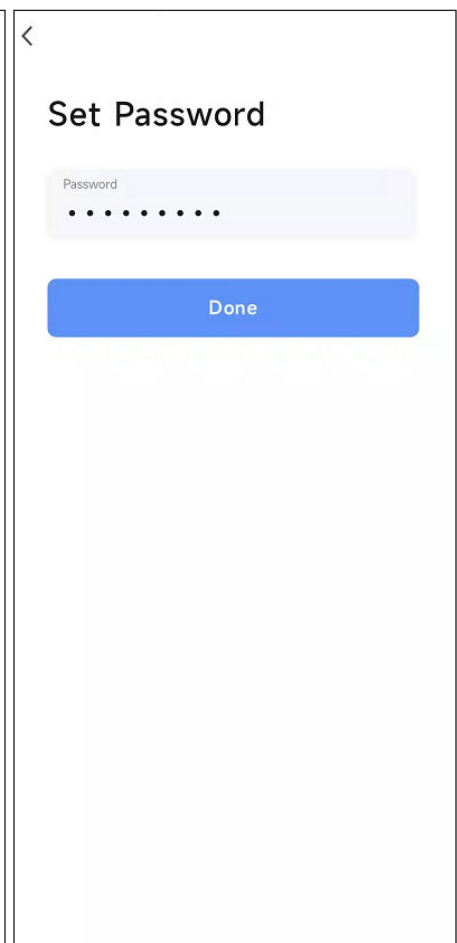
1. Press on the "Sign Up" button at the bottom of the screen, as shown in the picture 1.
2. The system automatically recognizes your country/ area. You can also select your country code manually. Enter your mobile phone number/ email address and tap "Get verification code", as shown in the picture 2.
3. If you choose the mobile number option, then enter the verification code in the message sent to you by SMS. Set a password as prompted and press "Done" to finish your registration. as shown in the picture.



Picture 1




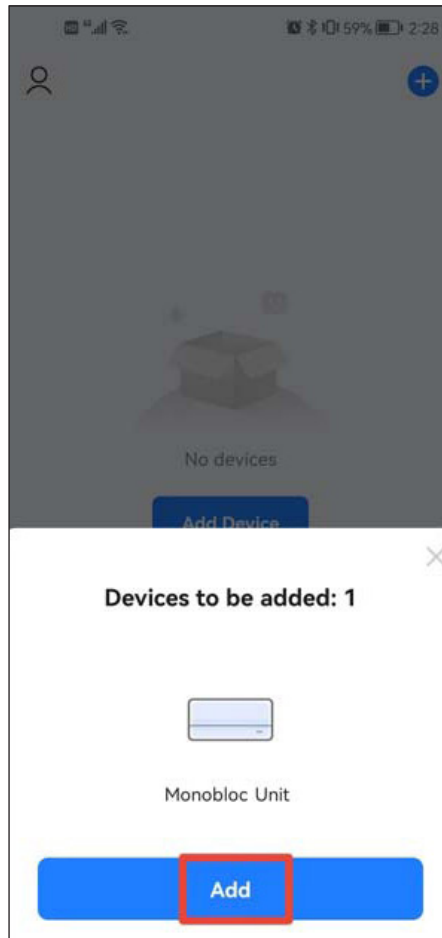
Picture 2



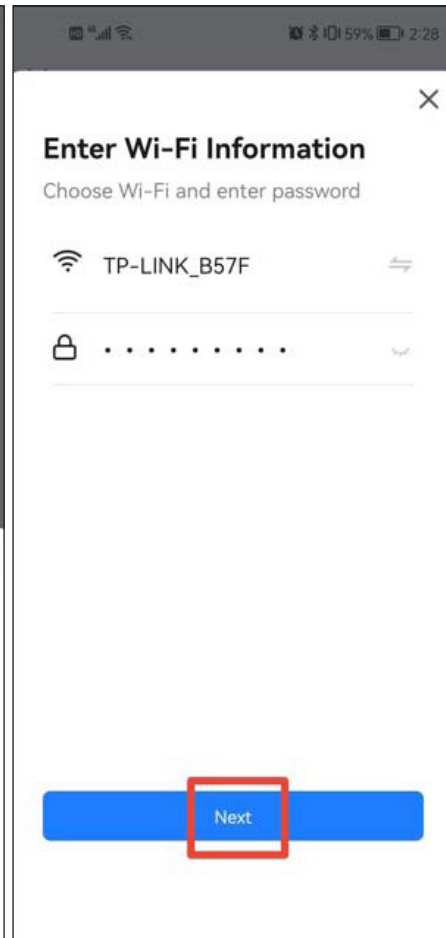
Picture 3

Connecting Using WIFI

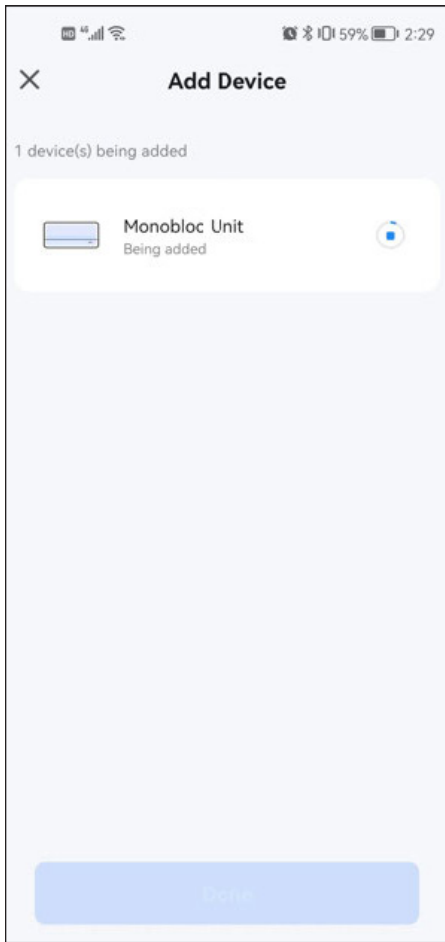
1. Prior to operating the unit with the app, you must follow the below steps to ensure the unit is in “connection, or pairing” mode. To pair the unit to your device, ensure the unit is in “standby” mode. The screen on the local unit should be “greyed” out and there should be no call or demand. Press and hold the “fan or fan speed button” for 3 seconds until an audible “beep” is heard. In the upper right hand corner of the screen a wifi symbol  should flash. This indicates the unit is in pairing mode and ready to proceed to the next steps. If this does not work, try un-plugging the unit and re-plugging it and ensuring the unit is in standby mode. If this is successful the WiFi symbol shall be solid and no longer flashing
2. Open the Smart Life App (instructions to download above) and the app should recognize a unit (Monobloc unit) is ready to be added (see picture 4). If this is successful, follow the prompts in the app (pictures 5-8) to successfully add the monobloc unit. If this is not successful, please continue to step 3.
3. Add a unit manually- If step 2 is unsuccessful, you can manually add a device.



Picture 4



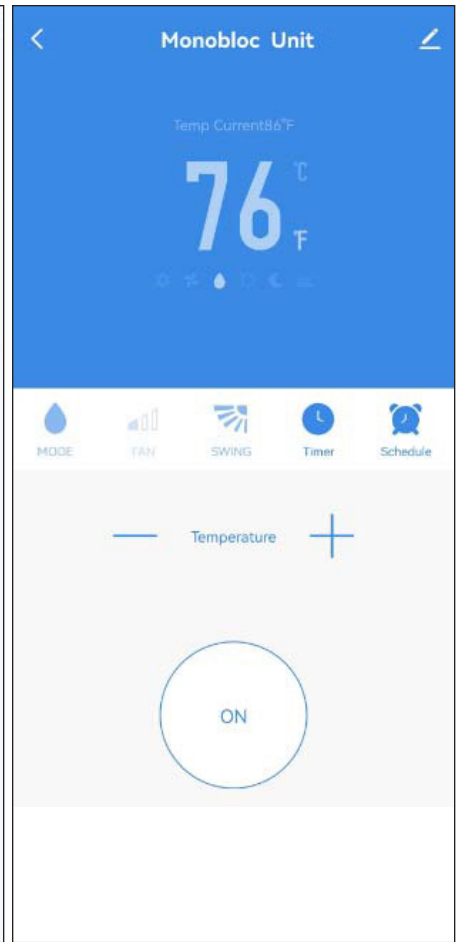
Picture 5



Picture 6

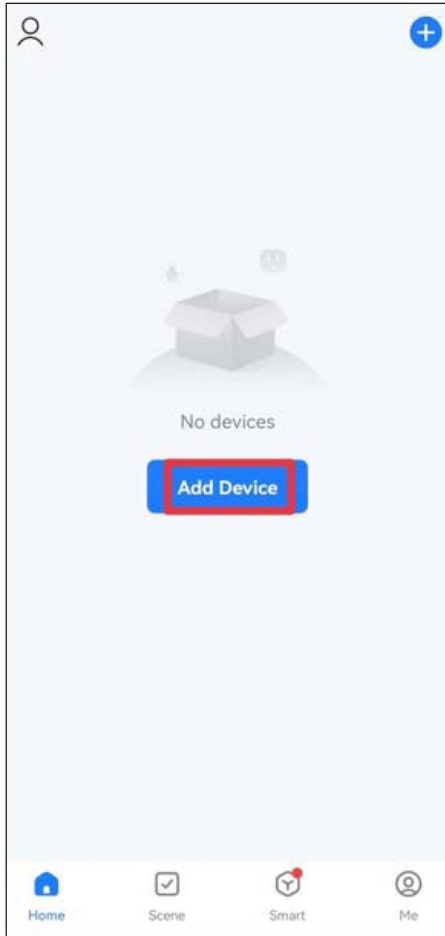


Picture 7



Picture 8

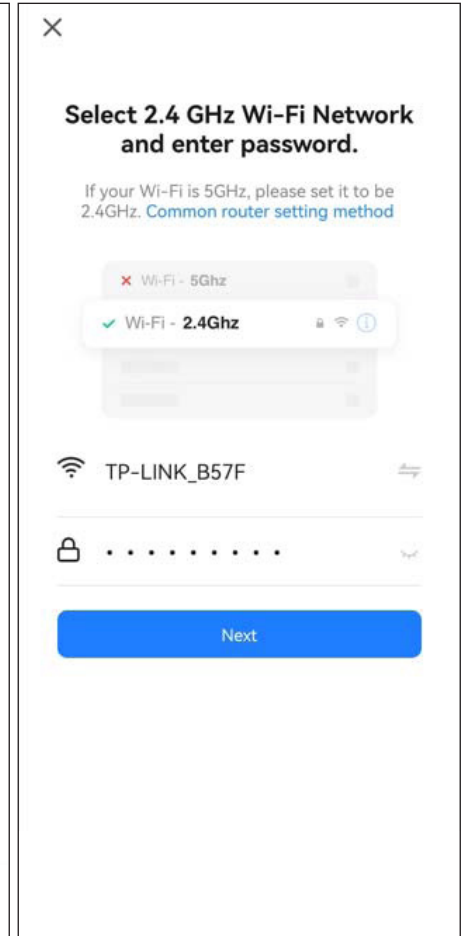
1. Click "Add Device" for operation, as shown in the picture 10.
2. Select the type of device as "Large Home Appliance", as shown in the picture 11.
3. Connect a WIFI and enter the password., as shown in the picture 12.
 - a. Click "Add Device" for operation (Picture 9).
 - b. Select the type of device as "Large Home Appliance" (Picture 10).
 - c. Connect a WIFI and enter the password (Picture 11).
 - d. Ensure the WIFI light on the unit is flashing twice per second (Picture 12).
 - e. Enter the device connection interface after the progress bar is finished and the device is successfully connected. Click the "Done" button to enter the operation interface of the device (Picture 13 and 14).



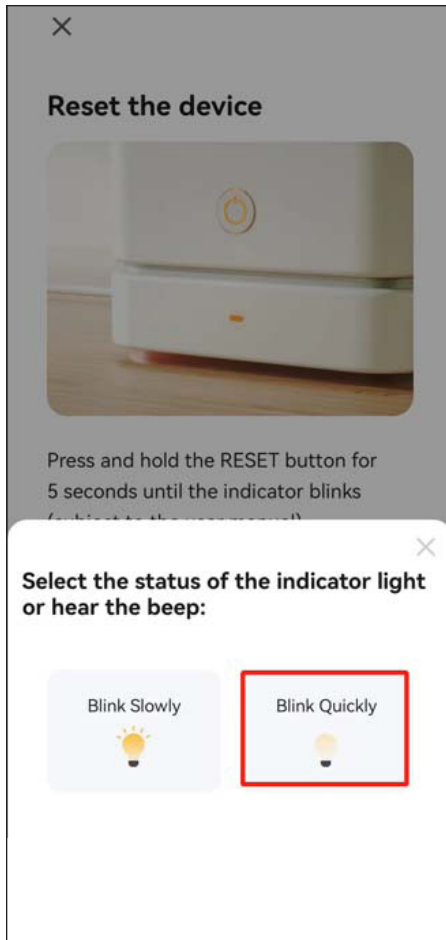
Picture 9



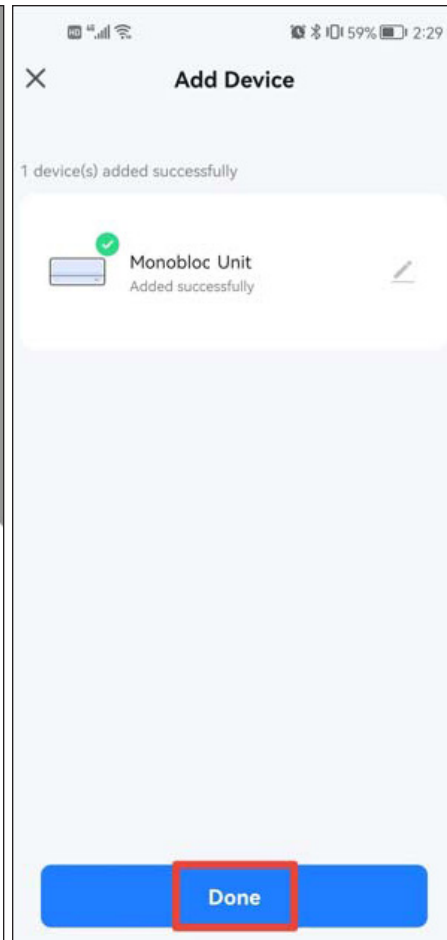
Picture 10



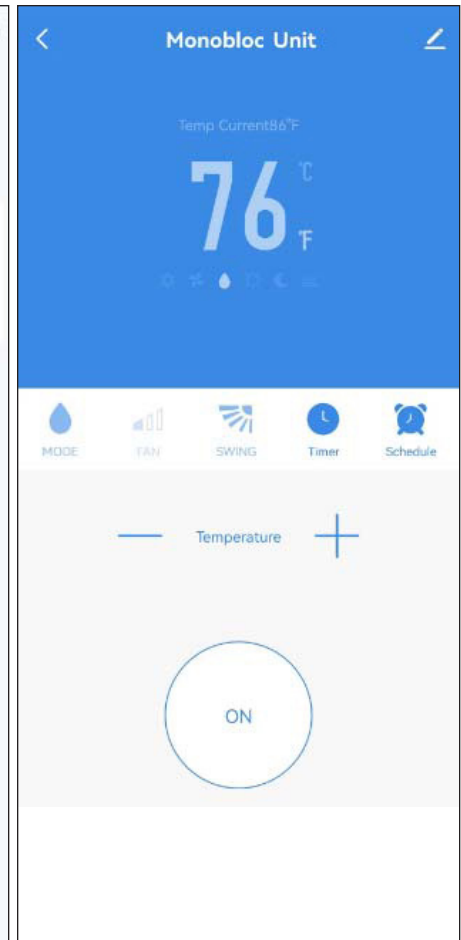
Picture 11



Picture 12



Picture 13



Picture 14

4. Ensure the WIFI light on the unit is flashing twice per second, as shown in the picture 12.
5. Enter the device connection interface after the progress bar is finished and the device is successfully connected. Click the "Done" button to enter the operation interface of the device, as shown in the picture 13, 14.

Due to continuous development of the app, the layout and available features may be subject to change.

Troubleshooting

Do not repair or disassemble the unit without proper troubleshooting steps and contacting a qualified maintenance person. Unqualified repair will invalidate the warranty and may lead to failure, causing injuries and property damage. Only use it as directed in this user manual and only perform operations advised here.

If problems not listed in the table occur or recommended solutions do not work, please contact the service center.

Problem	Reasons	Solutions
The unit does not work	There is no electricity.	Check the unit is plugged in, and the socket is working normally.
	The ambient temperature is too low or too high.	Only use to use the unit with a room temperature between 23 and 95°F.
	In cooling mode, the room temperature is lower than the desired temperature; in heating mode, the room temperature is higher than the desired temperature.	Adjust the desired room temperature.
	In dehumidification (dry) mode, the ambient temperature is low.	Ensure that the room temperature is above 62°F for dry mode.
	There is direct sunlight.	Use curtains to reduce heat from the sun.
Poor heating or cooling	Doors or windows are open; there are a lot of people; or in cooling mode, there are other sources of heat (e.g. fridges)	Close doors and windows; increase air conditioning power
	The filters screen is dirty.	Clean or replace the filter screen.
	The air inlet or outlet is blocked.	Clear obstructions; make sure the unit is installed as per the instructions
The unit is leaking	The unit is not straight.	Use a level to check the unit is horizontal, if not remove from the wall and straiten.
	The drainpipe is blocked.	Check the drainpipe to ensure it is not blocked or constricted.
Compressor does not work.	Overheat protection operational.	Wait for 3 minutes until the temperature is lowered, and then restart the unit.
The remote control does not work.	The remote control is not aligned with the direction of the remote-control receiver.	Move the remote control closer to the unit in question. The remote can be used for other units, ensure the remote is aimed at the unit needed to be operated and reacts accordingly.
	Batteries poor.	Replace batteries.

Resistance - Temperature Conversion Table

R25=5.0k Ω \pm 1%

B25/50=3470k \pm 1%

T [°C]	Rmin [k Ω]	Rnom [k Ω]	Rmax [k Ω]
-30	60.21	62.37	64.61
-29	57.07	59.09	61.17
-28	54.11	55.99	57.94
-27	51.32	53.08	54.89
-26	48.70	50.34	52.03
-25	46.22	47.75	49.33
-24	43.88	45.31	46.79
-23	41.68	43.02	44.39
-22	39.60	40.85	42.13
-21	37.63	38.80	40.00
-20	35.78	36.87	37.99
-19	34.03	35.05	36.09
-18	32.37	33.32	34.30
-17	30.80	31.69	32.61
-16	29.32	30.16	31.01
-15	27.92	28.70	29.50
-14	26.59	27.32	28.07
-13	25.34	26.02	26.72
-12	24.15	24.79	25.44
-11	23.02	23.62	24.23
-10	21.96	22.51	23.08
-9	20.95	21.47	22.00
-8	19.99	20.47	20.97
-7	19.08	19.53	20.00
-6	18.21	18.64	19.08
-5	17.40	17.80	18.20
-4	16.62	16.99	17.37
-3	15.88	16.23	16.59
-2	15.18	15.51	15.84
-1	14.51	14.82	15.13
0	13.88	14.17	14.46
1	13.28	13.55	13.82
2	12.71	12.96	13.21
3	12.16	12.40	12.63
4	11.64	11.86	12.09
5	11.15	11.36	11.56
6	10.68	10.87	11.07
7	10.24	10.41	10.60
8	9.809	9.977	10.15
9	9.404	9.561	9.719
10	9.018	9.164	9.312
11	8.650	8.786	8.924
12	8.298	8.426	8.555

T [°C]	Rmin [kΩ]	Rnom [kΩ]	Rmax [kΩ]
13	7.964	8.083	8.203
14	7.644	7.755	7.867
15	7.339	7.443	7.547
16	7.048	7.145	7.242
17	6.771	6.861	6.951
18	6.505	6.589	6.673
19	6.252	6.330	6.408
20	6.010	6.082	6.155
21	5.778	5.846	5.914
22	5.557	5.620	5.683
23	5.346	5.404	5.462
24	5.144	5.197	5.251
25	4.950	5.000	5.050
26	4.761	4.811	4.861
27	4.581	4.630	4.680
28	4.408	4.457	4.507
29	4.243	4.292	4.341
30	4.084	4.133	4.183
31	3.933	3.982	4.031
32	3.788	3.836	3.885
33	3.649	3.697	3.745
34	3.516	3.563	3.611
35	3.388	3.435	3.483
36	3.266	3.313	3.360
37	3.149	3.195	3.242
38	3.037	3.082	3.128
39	2.929	2.974	3.019
40	2.826	2.870	2.915
41	2.726	2.770	2.815
42	2.631	2.675	2.718
43	2.540	2.583	2.626
44	2.452	2.494	2.537
45	2.368	2.409	2.451
46	2.287	2.328	2.369
47	2.209	2.249	2.290
48	2.135	2.174	2.214
49	2.063	2.102	2.141
50	1.994	2.032	2.071
51	1.927	1.965	2.003
52	1.863	1.901	1.938
53	1.802	1.839	1.876
54	1.743	1.779	1.815
55	1.686	1.721	1.757
56	1.631	1.666	1.701
57	1.579	1.613	1.647
58	1.528	1.561	1.595
59	1.479	1.512	1.545
60	1.432	1.464	1.497
61	1.387	1.418	1.451

T [°C]	Rmin [kΩ]	Rnom [kΩ]	Rmax [kΩ]
62	1.343	1.374	1.406
63	1.301	1.331	1.363
64	1.260	1.290	1.321
65	1.221	1.250	1.281
66	1.183	1.212	1.242
67	1.147	1.175	1.204
68	1.112	1.140	1.168
69	1.078	1.105	1.133
70	1.045	1.072	1.100
71	1.013	1.040	1.067
72	0.9830	1.009	1.036
73	0.9536	0.9791	1.005
74	0.9252	0.9502	0.9758
75	0.8978	0.9223	0.9474
76	0.8713	0.8953	0.9200
77	0.8457	0.8693	0.8935
78	0.8209	0.8441	0.8678
79	0.7970	0.8198	0.8431
80	0.7739	0.7962	0.8191
81	0.7516	0.7735	0.7959
82	0.7300	0.7515	0.7735
83	0.7091	0.7302	0.7518
84	0.6889	0.7096	0.7308
85	0.6694	0.6897	0.7105
86	0.6505	0.6704	0.6908
87	0.6322	0.6517	0.6718
88	0.6145	0.6337	0.6534
89	0.5974	0.6162	0.6355
90	0.5808	0.5992	0.6182
91	0.5648	0.5828	0.6015
92	0.5492	0.5670	0.5852
93	0.5342	0.5516	0.5695
94	0.5196	0.5367	0.5543
95	0.5055	0.5222	0.5395
96	0.4918	0.5083	0.5252
97	0.4785	0.4947	0.5113
98	0.4657	0.4815	0.4979
99	0.4533	0.4688	0.4848
100	0.4412	0.4564	0.4722
101	0.4295	0.4445	0.4599
102	0.4181	0.4328	0.4480
103	0.4071	0.4216	0.4364
104	0.3965	0.4106	0.4252
105	0.3861	0.4000	0.4143

Error Codes

F1	Compressor IPM error	The drive module of compressor is failed or has faulty wiring	check all wiring connections for faulty wiring. If wiring is acceptable, change the main control board
F2	PFC/IPM error	PFC/IPM error	Power cycle the unit. If error persists, change the main control board
F3	Compressor start error	The compressor start process has failed.	Check wiring connections for loose or faulty wiring. If wiring is ok, change the main control board
F4	Compressor running out of step	The compressor running abnormally	Check for continuity on compressor winding. If windings are open, replace compressor. Check for loose or faulty wiring. If wiring is ok, change main control board.
F5	Location detection loop failure	Location detection loop failure (Receive signal that compressor not in place or receive no signal)	Check for continuity on compressor winding. If windings are open, replace compressor. Check for loose or faulty wiring. If wiring is ok, change main control board.
F6	PCB and driver board communication error	PCB and driver board communication error	Check all wiring connections for loose or faulty wiring. If wiring is ok, change the main control board
F7	Coil sensor error(outdoor)	Coil sensor error(outdoor)	Verify sensor are in proper location, wired correctly with no loose connections. Check sensor ohm's for proper resistance (5k sensor) against temperature chart when not connected to control board. If location is proper, and wiring is good, change sensor.
F8	Sensor on suction pipe error	Sensor on suction pipe error	Verify sensor are in proper location, wired correctly with no loose connections. Check sensor ohm's for proper resistance (5k sensor) against temperature chart when not connected to control board. If location is proper, and wiring is good, change sensor.
FA	Phase current overcurrent protection	Phase current overcurrent protection	Indicates a high current. Verify proper voltage, proper refrigerant charge, check for blockage or restrictions in air flow (indoors and outdoors). Unit may be oversized for application. Unit is operating outside of the recommended ambient or room temperature range.
FE	EE error(outdoor)	EE error(outdoor) (read signal which doesn't match the data preserved in chip or failed to read)	Swap main control board
FL	Water-full protection	The condenser water full protection	Condensate pan is full. Drain condensate pan. Check/verify wiring is not loose or broken.
P2	Dc bus voltage Undervoltage protection	Undervoltage protection	Verify supply voltage is within 10% of rating plate. If not in range, supply with proper/stable voltage. If appropriate, change main control board
P3	AC Input voltage protection	AC Input voltage protection	Verify supply voltage is within 10% of rating plate. If not in range, supply with proper/stable voltage. If appropriate, change main control board
P4	AC over-current protection	AC over-current protection	Verify supply voltage is within 10% of rating plate. If not in range, supply with proper/stable voltage. If appropriate, change main control board
P5	AC undervoltage protection	AC undervoltage protection	Verify supply voltage is within 10% of rating plate. If not in range, supply with proper/stable voltage. If appropriate, change main control board
P6	Coil tube overload protection(indoor)	Indoor coil overload protection	Check for air blockage or debris on air outlet.
P7	Compressor IPM error P7 Defrost protection on coil tube(indoor)	Indoor coil freeze protection	Verify fan is running at appropriate speeds. If fan is not running, check for proper voltage and demand from controller. Replace fan or fan motor if damaged. Check for debris or dirty coil and/or fan blades. Clean with appropriate cleaning products as needed. Check for leaks in refrigerant system. If a leak is found, repair and re-charge R32 refrigerant using proper charging techniques. Call for factory assistance as needed.
PC	Coil tube overload protection(outdoor)	Outdoor coil overload protection(1. The outdoor temperature is not allowed to exceed 43°C; 2. Check whether the ventilation outside the room is smooth; 3. Is the outdoor coil sensor damaged)	Check for fan blockage or improper operation of outdoor outlet fan. Repair/replace as needed. Verify sensor is in proper location and reading properly (against 5k temp/ohm chart) repair or replace as needed
PH	Exhaust temperature protection	Gas discharge temperature protection	Power off and wait for 1 minute to turn on again will clear this protection. If error returns, check sensor for proper reading and pressures for proper pressures. Repair sensors if needed. If sensors reading correctly, check coil (evap or condenser depending on mode) for debris. Check blower for proper functions. Repair or replace as needed.
E0	Sensor on suction pipe error	The sensor on gas discharge side is failed	Verify sensor are in proper location, wired correctly with no loose connections. Check sensor ohm's for proper resistance (5k sensor) against temperature chart when not connected to control board. If location is proper, and wiring is good, change sensor.

Error Codes (continued)

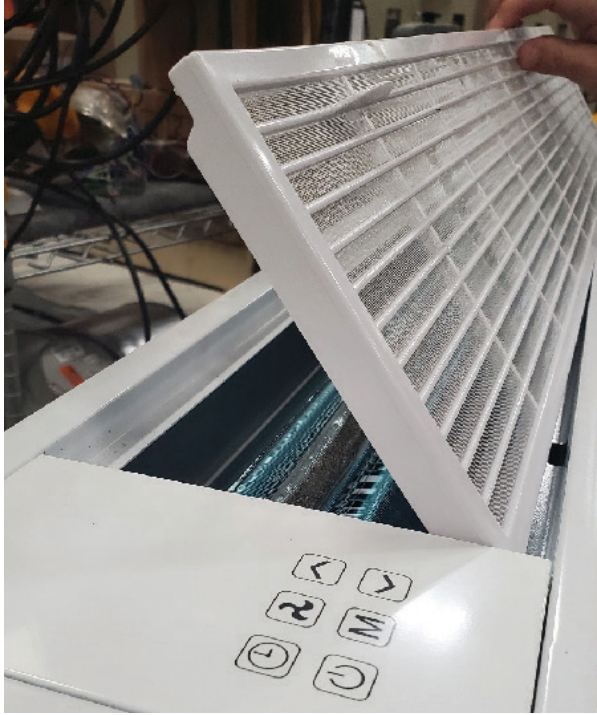
E1	Temperature sensor error(indoor)	The room temperature sensor is failed	Verify sensor are in proper location, wired correctly with no loose connections. Check sensor ohm's for proper resistance (5k sensor) against temperature chart when not connected to control board. If location is proper, and wiring is good, change sensor.
E2	Sensor error on indoor coil tube	The sensor on the indoor coil is failed	Verify sensor are in proper location, wired correctly with no loose connections. Check sensor ohm's for proper resistance (5k sensor) against temperature chart when not connected to control board. If location is proper, and wiring is good, change sensor.
E3	DC fan Feedback failure(indoor)	The fan motor of indoor side is failed	Verify sensor are in proper location, wired correctly with no loose connections. Check sensor ohm's for proper resistance (5k sensor) against temperature chart when not connected to control board. If location is proper, and wiring is good, change sensor.
E4	Indoor and outdoor communication error	The communication between indoor & outdoor side is failed	Verify proper connection for the communication wires. Repair/replace as needed.
E5	Water-splash motor error	The Water-splash motor is failed	change the Water-splash motor wiring for good connection. Check the wiring and wheel for damages. Repair/replace if needed.
E6	Temperature sensor error(outdoor)	The ambient temperature sensor is failed	Verify sensor are in proper location, wired correctly with no loose connections. Check sensor ohm's for proper resistance (5k sensor) against temperature chart when not connected to control board. If location is proper, and wiring is good, change sensor.
E7	Fan motor error(outdoor)	The fan motor of outdoor side is failed	Verify proper wiring and wiring location. Repair/replace wiring as needed. If wiring is ok, ohm motor windings. If open, replace motor.
E8	Fan feedback fault	The cooling fan is failed	Verify proper wiring and wiring location. Repair/replace wiring as needed. If wiring is ok, ohm fan motor windings. If open, replace fan.
E9	Wifi Check	Someone has pressed the "up arrow" and the "mode" button simultaneously.	This function is used for a check in production. There is no error. Unit will need power cycled to clear the fault. If the fault does not clear, replace main PCB.
EE	EE error(indoor)	EE error(indoor) (read signal which doesn't match the data pre-saved in chip or failed to read)	Verify wiring, repair/replace as needed. If wiring is ok, change the main control board
Eb	Refrigerant Charge Protection / Indoor Coil Protection	Coil freezing, Drop in cooling capacity, AC blowing hot air, Hissing noise from unit	Call technician to inspect unit for possible leak or under-charge situation. If leak is found, repair and recharge R32 refrigerant. If no leak is found, recharge unit using proper charging techniques. Call factory for assistance as needed.

Servicing

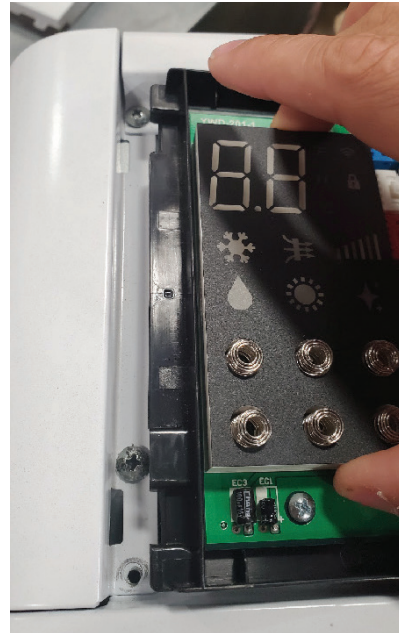
To access the main control board (PCB) and wiring compartment please follow the steps below.

CAUTION All troubleshooting and diagnosing should be done by a qualified professional service technician or installer. If any doubt, please contact Designline tech support. The below steps should be conducted with the power removed from the unit to ensure the safety of the technician from electrical hazards.

1. Remove top filter and set aside to keep safe.



3. Gently remove the main control touch panel exposing the underlayment. Gently slide the underlayment away, take care not to disconnect any wiring harnesses, exposing two (2) mounting screws. Remove these and set aside to keep safe.



2. Remove 2 screw located to the right of the main control panel. Set aside to keep safe.



4. Once removed, the side panel can now be pushed down and removed from the unit exposing the cover panel for the control board section.



5. Remove five (5) mounting screws located around the perimeter of this cover panel to expose the main control wiring and PCB. Set screws aside to keep safe.



6. To replace, reverse these instructions securing the panels to the unit as required.

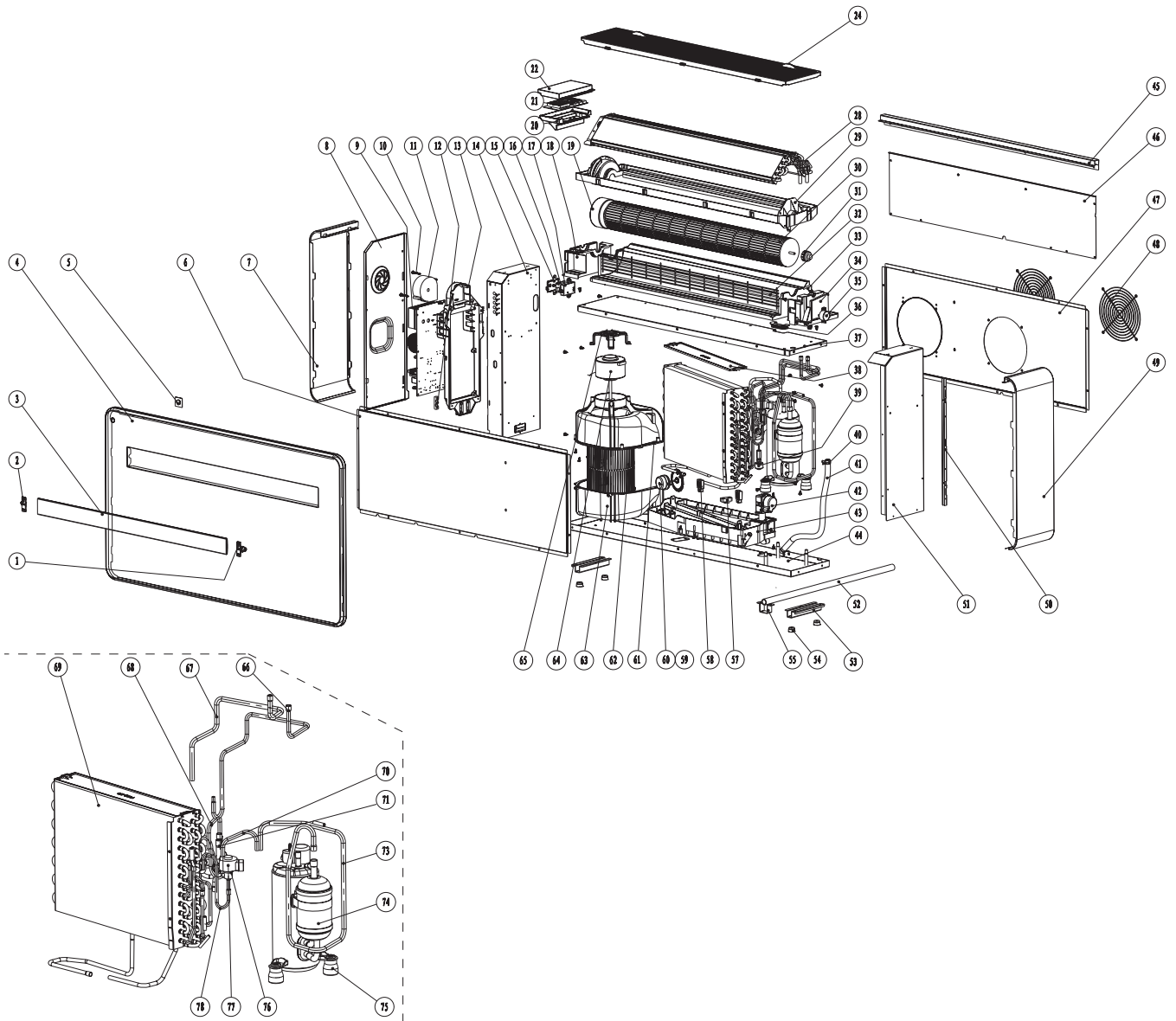
General Maintenance:

- Clear inlets and outlets
- Check condensate lines
- Clean grill
- Make sure it's still level

CAUTION When disposing of this product, the following information must be followed:








Due to the nature of the refrigerant in this unit, it is prohibited to dispose of this appliance as "household" waste. Please contact your local municipality to determine the proper way of disposal. Or reach out to your supplier for more information.

Replacement Parts



MHP Parts Breakdown List

Number	Description	Part Number
1	Discharge Vane Guard	55W41-DL0016-10
2	Discharge Vane Stop	55W41-DL0017-10
3	Discharge Vane	55W41-DL0018-10
4	IR Receiver	55W48-DL0019-10
5	Front Panel	55W41-DL0020-10
6	Front Cover	55W41-DL0021-10
7	Left Cover	55W41-DL0022-10
8	Electronic Control Box Cover	55W41-DL0023-10
9	Variable Frequency Drive Plate	55W09-DL0024-10
10	Securing Screw	55W21-DL0025-10
11	Electronic Cooling Fan	55W34-DL0026-10
12	Wire Clamp	55W09-DL0027-10
13	Plastic Electric Control Box	55W41-DL0028-10
14	Left Support Plate	55W41-DL0029-10
15	Wifi Protection Box Cover	55W41-DL0030-10
16	Wifi Module	55W11-DL0010-10
17	Wifi Protective Box	55W41-DL0031-10
18	Left Blower Support Base	55W41-DL0032-10
19	Indoor Fan Motor (BrushlessDC)	55W31-DL0014-10
20	Display Mounting Box	55W41-DL0034-10
21	Display Panel	55W41-DL0035-10
22	Touchscreen	55W41-DL0036-10
24	Indoor Filter	55W27-DL0013-10
28	Evaporator Assembly	55W50-DL0038-10
29	Drain Pan	55W06-DL0039-10
30	Supply Air Turbine	55W34-DL0040-10
31	Rotor Shaft Sleeve	55W41-DL0041-10
32	Supply Fan Guard	55W41-DL0042-10
33	Foam Air Duct	55Y03-DL0043-10
34	Right Blower Support	55W41-DL0044-10
35	Stepper Motor	55W31-DL0012-10
36	Rubber Middle Partition Seal	55Y03-DL0045-10
37	Partition	55W41-DL0046-10
38	Condenser Cover	55W41-DL0047-10
39	Float Switch	55W11-DL0048-10
40	C-Clamp	55W26-DL0049-10
41	Rubber Drain Pipe	55W06-DL0050-10
42	Drain Pump	55W11-DL0051-10
43	Drain Pan Assembly	55W20-DL0052-10
44	Base	55W41-DL0053-10
45	Mounting Bracket	55W41-DL0054-10
46	Cover Plate	55W41-DL0055-10
47	Back Panel	55W41-DL0056-10
48	Rear Blower Guard	55W27-DL0057-10
49	Right Cover	55W41-DL0058-10
50	Right Link Bar	55W41-DL0059-10
51	Right Support Plate	55W41-DL0060-10
52	Drain Pipe	55W06-DL0061-10
53	Chassis Supports	55W41-DL0062-10
54	Rubber Feet	55W41-DL0063-10
55	Drain Support	55W16-DL0064-10
57	Rubber Support Block 1	55W41-DL0065-10
58	Rubber Support Block 2	55W41-DL0066-10
59	Cond Evap Wheel	55W34-DL0067-10
60	Cond Evap Motor	55W31-DL0068-10
61	Blower Top Air Duct	55W15-DL0069-10
62	Outdoor Blower Wheel	55W34-DL0070-10
63	Blower Bottom AirDuct	55W15-DL0071-10
64	Outdoor Fan Mtr (BrushlessDC)	55W31-DL0015-10
65	OD Air Motor Bracket	55W32-DL0073-10
66	EEV Formed Pipe	55W28-DL0074-10
67	4-Way Valve Connection 2	55W28-DL0075-10
68	4-Way Valve Connection 1	55W28-DL0076-10
69	Condenser Coil Assembly	55W50-DL0077-10
70	Compressor Discharge Pipe	55Y07-DL0078-10
71	Four-Way Valve	55W28-DL0079-10
73	Compressor Suction Pipe	55W33-DL0081-10
74	Compressor	55W33-DL0082-10
75	Compressor Support	55W33-DL0083-10
76	EEV Solenoid Coil	55W50-DL0084-10
77	EEV	55W28-DL0085-10
78	EEV Bottom Formed Pipe	55W28-DL0086-10

Items not Shown		
Description	Part Number	Image
Indoor Duct Collar	55W15-DL0001-10	
Outdoor Round Grill	55W15-DL0002-10	
Spring	55W15-DL0003-10	
Chain	55W15-DL0004-10	
Install Wall Template	55W30-DL0005-10	
Plastic Ducting Sheets (2)	55W15-DL0006-10	
Remote Control	55W48-DL0007-10	
Main Control Board (PCB)	55W11-DL0008-10	
Display	55Y11-DL0009-10	
Outdoor Air In Sensor (5K)	55W09-DL0011-10	
Indoor Sensor Assy Temp/Coil5K	55W09-DL0033-10	
Outdoor Ambient Temp Sensor 5K	55W09-DL0037-10	
OD Air Disch Sensor 5K	55W09-DL0072-10	
OD Coil Temp Sensor 5K	55W09-DL0080-10	

LIMITED WARRANTY

Subject to the terms and conditions of this Limited Warranty Statement (the “Limited Warranty”), DesignLine warrants to the ORIGINAL PURCHASER of the “MHP-10”.

For purposes of this Limited Warranty, as used herein, the term “System” shall mean the MHP-10 outdoor and indoor components connected via refrigerant piping and electrical wiring purchased on or after DATE, (i) sold from a licensed HVAC representative of DesignLine (and not an unauthorized third party) to the original owner, (ii) installed by such contractor in accordance with local and National regulations in the continental U.S., Alaska, Hawaii, and Canada

This warranty is only valid when both conditions below are met:

- System sold from a licensed HVAC representative of DesignLine to the original owner
- Installed by such contractor in accordance with local and National regulations in the continental U.S., Alaska, Hawaii, and Canada

Parts Warranty (One Year)

The parts are warranted for a period of one year to the original owner of the system. If any parts should prove defective due to improper workmanship and/or material for a period of one year from the date of installation, DesignLine will replace any defective part without charge for that part. Replacement parts are warranted for the remainder of the original one year warranty period. Parts used as replacement may be of like kind and quality and may be new or remanufactured. Defective parts must be available for DesignLine in exchange for the replacement parts and become the property of DesignLine.

Compressor Warranty (Three Year)

The compressor is warranted for a period of three years to the original owner of the system. If the compressor should prove defective due to improper workmanship and/or material for a period of three years from the date of installation, DesignLine will replace the defective compressor without charge for the compressor. Replacement compressors are warranted for the remainder of the original three year warranty period. Compressors must be made available to DesignLine in exchange for the replacement compressor and become the property of DesignLine.

No Labor

Each Limited Warranty offered by DesignLine does NOT include labor or any other costs incurred for service, maintenance, repair, removing, replacing, installing, complying with local building and electrical codes, shipping or handling, or replacement of the System, compressors, or any other parts. For items that are designed to be maintained or replaced by the original owner, the original owner is solely responsible for all labor and other costs of maintaining, installing, replacing, disconnecting, or dismantling the System and all parts in connection with owner-required maintenance.

Proper Installation

This Limited Warranty applies only to DesignLine Systems that are sold by DesignLine HVAC representative, installed by contractors who are licensed for HVAC installation under applicable local and state law, and who install the Systems in accordance with (i) all applicable building codes and permits; (ii) DesignLine's installation and operation instructions; and (iii) good trade practices.

Before Requesting Service

Please review the applicable technical documentation to ensure proper installation and correct customer control adjustment for the System. If the problem persists, please arrange for warranty service.

a. To Obtain Warranty Service:

- Contact the licensed contractor who installed the System or the nearest licensed contractor, dealer, or distributor (whose name and address may be obtained on our website www.designlineonline.com of any defect within the applicable warranty time period.
- Proof of the installation date by a licensed contractor is required when requesting warranty service. Present the sales receipt, building permit or other document which establishes proof and date of installation. In the absence of acceptable proof, this Limited Warranty shall be deemed to begin 90 days after the date of manufacture stamped on the System.
- This Limited Warranty applies only to Systems purchase on or after January 1, 2024 only while the System remains at the site of the original installation, and only to locations within the continental United States, Alaska, Hawaii, and Canada.
- Shipment, to the Manufacturer, of that part of the System thought to be defective. Goods can only be returned with prior written approval from the Manufacturer. All returns must be freight prepaid. Determination, in the reasonable opinion of the Manufacturer, that there exists a defect in material or workmanship.

b. This Limited Warranty Does Not Cover:

- Property damages, malfunction or failure of the System, or personal injury caused by or resulting from: (a) accident, abuse, negligence, or misuse; (b) operating the System in a corrosive or wet environment, including those containing chlorine, fluorine, or any other hazardous or harmful chemicals or environmental factors, including sea- or salt-water; (c) installation, alteration, repair, or service by anyone other than a licensed contractor or other than pursuant to the manufacturer's instructions; (d) improper matching of System components; (e) improper sizing of the System; (f) improper or deferred maintenance contrary to the manufacturer's instructions; (g) physical abuse to or misuse of the System (including failure to perform any maintenance as described in the Operation manual, or any System damaged by excessive physical or electrical stress; (h) Systems that have had a serial number or any part thereof altered, defaced, or removed; (i) Systems used in any manner contrary to the Operation Manual; (j) freight damage; or (k) events of force majeure or damage caused by other external factors such as lightning, power surges, fluctuations in or interruptions of electrical power, rodents, vermin, insects, or other animal – or pest-related issues.

c. This Limited Warranty Also Excludes:

- (a) SERVICE CALLS WHERE NO DEFECT IN THE SYSTEM COVERED UNDER WARRANTY IS FOUND; (b) System installation or set-ups; (c) Adjustments of user controls; (d) Systems purchased or installed outside the continental United States, Alaska, Hawaii, and Canada; or (e) Systems purchased or installed prior to DATE. Consult the operating instructions for information regarding user controls.

This Limited Warranty does not cover any additional responsibilities or obligations not expressly stated herein nor does it apply to any accessor that is not a part of the System as included in the package by DesignLine.

Consult factory for optional extended warranty coverage pricing (5, 10, and 15 years)

DesignLine[®]



A MESTEK COMPANY

260 North Elm Street, Westfield, MA 01085
Tel: (413) 564-5545

7555 Tranmere Drive, Mississauga, Ontario, L5S 1L4 Canada
Tel: (905) 670-5888

www.designlinehvac.com